

Physikalisches Praktikum für Fortgeschrittene, Teil IIe

Radioastronomical Tasks

Contents

About this course

About radio astronomy

The radio sky, radio telescopes, radiation quantities

Instruments and software

Teleskopes

Observations with RoenneRadiometer (RRM)

Observations with RoenneSpektrometer (RSM)

Profile of the sky background

Basics, Observation, Analysis, Error considerations

Further objectives: Dependence on weather, Absorption of the Earth atmosphere

Surface temperature of the Sun

Basics, Observation, Analysis, Error considerations

Further objectives: Angular resolution, Radio flux of the Sun

Surface temperature of the Moon

Basics, Observation, Analysis, Error considerations

Further objectives: Monthly variations of the radio flux and surface temperature

Radio fluxes of other sky sources

Rotation curve of the Milky Way Galaxy

Basics, Observation, Analysis, Error considerations

Further objectives: Assumption of circular orbits, Rotation speed at $l=90^\circ$,

Comparison with a mass model, Rotation curve close to the Galactic Centre,

Mapping of spiral arms, Decomposition of spectra: spiral arms,

Deprojection of spiral arms

Literature

Text books, Articles, Weblinks

About this course

The aim of this practical course is to give an insight into radio astronomy and to learn essential methods of observations. With a telescope placed outside Kiel and thus well away from the city with its high level of electric and electronic noise, we measure the radio emission of the Sun, Moon, and our Milky Way Galaxy. Measuring the level of the continuum radiation (Radiometry) permits us to determine the surface temperatures of the Sun and the Moon, and the spectrometry in the Milky Way allows to derive the law of galactic rotation, which is one of the hints to the existence of 'dark matter'.

The observations are done in groups of 2 to 3 participants, on a computer in our institute, which controls the telescope remotely. For each task, we give an introduction to the subject to the use of the telescope, the software, the data reduction, and analysis. Since in radio astronomy we are essentially independent of daylight and the weather, we may plan observations simply when a source is above the local horizon. Since access to the real telescope must be coordinated with other users, we need to coordinate this with the instructor (JK). Because of certain peculiarities of the instrumentation and just in case of any serious problems, the instructor needs to be present during the observations.

In order to avoid the latter restriction, we shall use simulation software instead of the real telescope. This software models in a very realistic way the behaviour of the instrument as well as of electronic disturbances which may occur from the environment. It produces data in the same quality as the real instrument, and the simulated data is based on real data taken with the real telescope. As the software is accessible via the internet, and thus allows full 24 hour access to the user.

Further information and some other useful links and additional materiel are available on this webpage of the **Institut für Theoretische Physik und Astrophysik**
<http://www.astrophysik.uni-kiel.de/~koeppen/praktikum>

Hints for the practical operations

It is highly recommended to keep a detailed and accurate record during the observations – as one should always do during any other experiment. In order to avoid any uncertainties cropping up during the later analysis, it is advantageous to keep a written journal of all activities, reactions, results, and certainly about any unforeseen events. In this way it is easier to reconstruct or trace any possible errors. Never rely only on your – possibly: good – memory when later it must be understood what might have happened at this or that datum! The data files record the times, position of the telescope, and the measured values. Nonetheless you may want to note intermediate results – to compare with data taken a few minutes ago – or quick calculations, impressions, ideas, or things to do, etc. Paper or a text file are cheap and very patient ... while a number not written down may well be lost forever!!

About Radio Astronomy

The Radio Sky

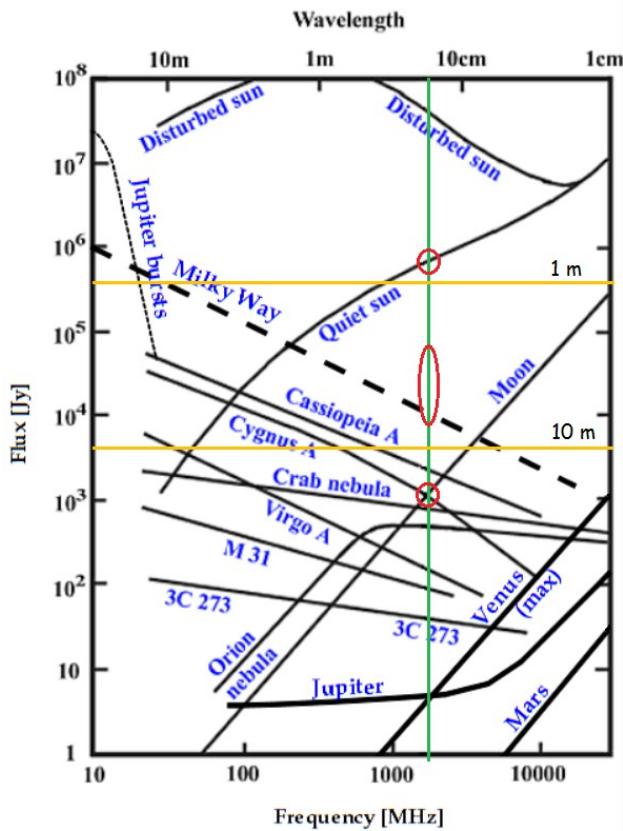

Fig.1: Spectral energy distributions of celestial objects in the radio range (after J.D.Kraus). The yellow lines indicate the sensitivity limits of telescopes with 1 and 10 m diameter and a detection threshold of 100 K in antenna temperature. The green line marks the spectral line of neutral hydrogen at 1420 MHz (21 cm wavelength), red ellipses show the objects which are to be observed in this course. For the Milky Way the continuum spectrum is shown, to which the 21 cm line is added.

Hint: This plot is available as an interactive graph at <http://www.astrophysik.uni-kiel.de/~koeppen/JS/KrausPlot.html>

If our eyes were sensitive to radio waves, we would see this: the ground, all buildings, trees, and persons would appear bright, due to their emission of thermal radiation, because the radio region is nothing but the continuation of the infrared range towards longer wavelengths. The sky would be very dark, because here would only be the radiation from the cosmic microwave background (CMB) with a temperature of 2.7 K. There would also be a similarly strong contribution by the thermal radiation of the Earth atmosphere, with the difference between day and night being much weaker than in visible light. The Sun would appear as a very bright disc, the Moon as a much weaker one, and the planets would be very small and very faint. Stars we would not see in the radio sky, but a few gaseous nebulae and galaxies would be very faint sources. At the wavelength of 21 cm the Milky Way would appear as a bright band, being brighter towards the Galactic Centre.

From the Earth surface we can receive the electromagnetic radio radiation of sky objects in the frequency range between 30 MHz to about 30 GHz, corresponding to wavelengths of 10 m to 1 cm. The lower frequency limit is due to the ionosphere, the upper one due to the absorption by molecules in the air.

In this radio window a number of sky objects are observable (Fig.1): The Sun is by far the brightest object. Apart from a quiet component of thermal radiation by photosphere, chromosphere, and corona it is brighter in active phases. The Moon and the planets also emit thermal radiation in a blackbody spectrum.

The plane of the Milky Way and external galaxies (M31), supernova remnants (CasA), quasars (3C273) and radio galaxies (Cygnus A, Virgo A) have a radio flux which decreases with frequency. This is due to synchrotron emission, which is produced when electrons are forced by magnetic fields onto circular trajectories.

The plasma in HII regions (Orion) becomes transparent at high frequencies, where the continuum spectrum is flat. At lower frequencies the region is optically thick, and thus shows a blackbody spectrum, rising with frequency.

Radio telescopes

Such instrument consists of an antenna to capture the radio waves and to convert them into an electrical signal, the receiver electronics to amplify and filter this signal, and a computer for the subsequent handling and storage of the data as well as for the control of the telescope.

As antenna often a parabolic reflector dish is used, which concentrates the radio waves into the focus, where a dipole or a horn picks them up. The oscillating electromagnetic field induces in the dipole an alternating voltage, which is amplified by a low-noise preamplifier and supplied to the receiver. The parabolic dish has the same task as the mirror of an optical telescope: First of all, it needs to pick up as much of the radio wave power as possible, but also to restrict the field of view to a sufficiently small region in the sky.

The feed antenna in the focus of a circular mirror with (geometrical) diameter D_{geo} illuminates a (hopefully large) part of it, with an effective diameter D_{eff} . The antenna thus has an effective capture area $A_{\text{eff}} = \pi (D_{\text{eff}}/2)^2$ and receives from an object with radiative flux F_v (see below) in a receiver bandwidth B the power:

$$P = B F_v A_{\text{eff}}/2$$

The factor 2 is due to the fact that a dipole is sensitive to electric fields only if they lie parallel to its length. Because of the wave nature of the radiation this mirror has a finite angular resolving power. In the radio region we characterize it by the width of the antenna beam (HPBW = Half-Power Beam Width) which is for a uniformly illuminated circular surface:

$$\text{HPBW} = 58.957^\circ \lambda/D_{\text{eff}}$$

How does this compare with Rayleigh's criterion of optical instruments?

Another very important parameter is the effective solid angle in which the antenna is sensitive

$$\Omega_A = \lambda^2/A_{\text{eff}} = \lambda^2 / (\pi D_{\text{eff}}^2/4) = \lambda^2 / (\pi/4 (58.957^\circ \lambda/\text{HPBW})^2) = 4/\pi * (\text{HPBW}/58.957^\circ)^2$$

This quantity can be determined from the directly measurable width HPBW of the antenna beam.

Radiation quantities

The emission of celestial objects is nothing but a more or less broad-band noise, whose strength can vary with time. The job of the telescope is to measure the level of this unmodulated signal. However, the electronics in the receiver – in particular the preamplifier – also produces broad-band noise by thermal motions in the conduction electrons and noise in the active semi-conductor elements (transistors). It is common and useful to characterize the power received by the telescope in terms of the temperature which would produce thermal noise at the same level. In the band width B this would be: kTB . Thus we may define the “antenna temperature” as

$$k T_{\text{ant}} B = P$$

All bodies with a physical temperature T emit thermal radiation, whose intensity (specific intensity, surface brightness, ...) is given by the blackbody spectrum

$$I_{\nu} = B_{\nu}(\nu, T) = 2h\nu^3/c^2 / (\exp(h\nu/kT) - 1) \approx 2kT \nu^2/c^2 = 2kT/\lambda^2 = 2760 T/\lambda^2$$

with the unit $\text{Wm}^{-2}\text{Hz}^{-1}\text{sr}^{-1}$. At the usual temperatures and in the radio range (since $h\nu/kT \ll 1$) one may approximate the full Planck function by the Rayleigh-Jeans law. With the convenient unit for radio astronomy 1 Jy (Jansky) = 10^{-26}Wm^{-2} for the flux we get the simple numerical expression with temperature in Kelvin and wavelength in Meter. Hence the intensity is directly proportional to temperature ... This is the origin for the common practice to think in terms of temperatures.

The intensity is the power emitted by a body into a unit solid angle and which we receive from it per unit solid angle. If a body – seen from us – fills out the solid angle Ω , its radiative flux (more precisely: flux density, often designated with S_{ν}) is

$$F_{\nu} = I_{\nu} \Omega$$

which depends on the distance. A spherical object with radius R, observed from a distance r, has the angular diameter $D_{\text{obj}} = 2 \arctan(R/r)$ and fills the solid angle $\Omega = \pi (R/r)^2$ [in sterad]. If the object is a point source ($\Omega < \Omega_A$), which is not resolved by the telescope, the power measured with a bandwidth B is

$$P = B F_{\nu} A_{\text{eff}}/2 = B I_{\nu} \Omega A_{\text{eff}}/2$$

Then the antenna temperature is the physical temperature of the body, reduced by the filling factor Ω/Ω_A :

$$T_{\text{ant}} = T \Omega/\Omega_A$$

However, if the object is an extended source, whose emission fills the antenna beam completely, we measure only the fraction picked up by the antenna beam:

$$P = B I_{\nu} \Omega_A A_{\text{eff}}/2 = B I_{\nu} \lambda^2/2 = B 2760 T$$

In this case the antenna temperature is equal to the physical temperature of the object (if it radiates thermal radiation only). This property we exploit for the flux calibration: The antenna temperature of the Earth soil or of a sufficiently large house would be directly measurable with a thermometre, and is about 290 K.

Instruments and Software

Telescopes

Here are some information about the telescopes of DL0SHF (<https://sat-sh.lernnetz.de/>) in Rönne – we would use the 9m dish on 1 GHz. The controls of all antennas have the same structure, sketched in Fig.2:

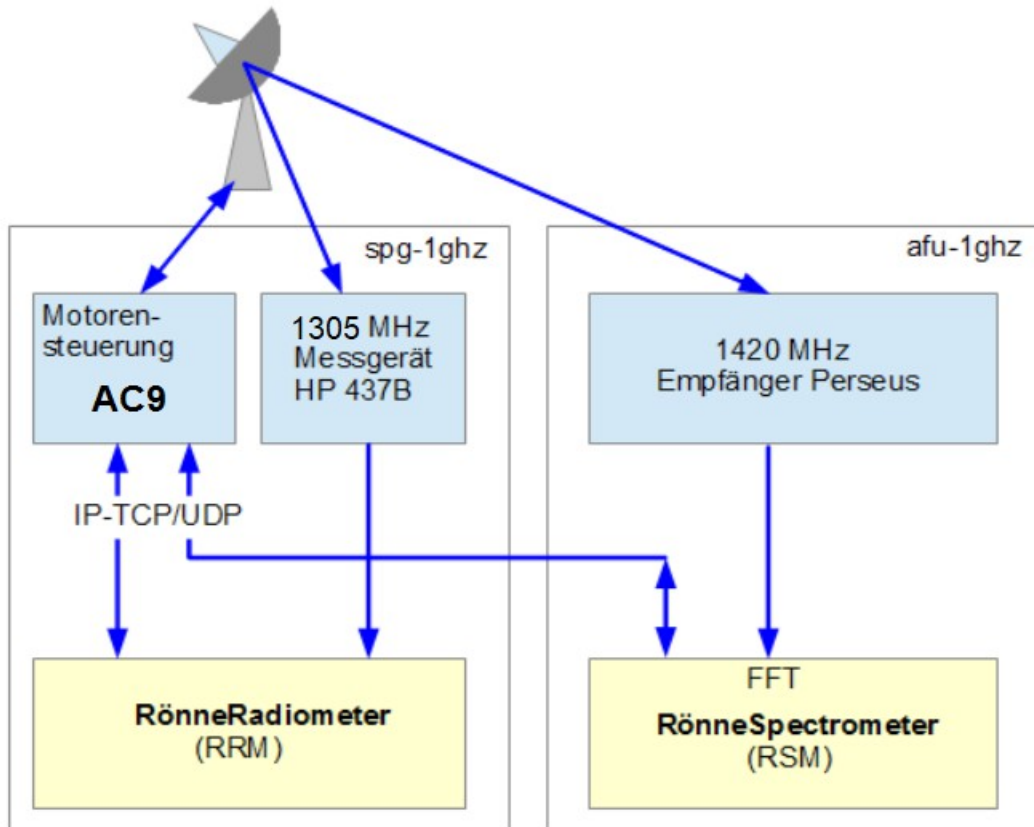

Fig.2: Overview of the control and measuring system of a radio telescope at DL0SHF

One computer ('spg') takes care of the control of the antenna motors, which is done by the program AntennaController AC9. We would not need to use it, except if problems appear, and thus it serves merely as a control display. On the same machine resides also the access to a HP437B power meter which measures the strength of the signal at 1305 MHz with a bandwidth of about 1.4 MHz. Its digital output is fed into our program RoenneRadiometer (RRM), which displays it and can record it. At the start of RRM the link to AC9 is automatically established, so that RRM also displays the current position of the antenna and allows us to control the motors to move to a new position.

A second computer deals with the control of the receiver. On the 1GHz antenna the reception on 1420 MHz is done with a software-defined radio Perseus. This device digitizes the signals in a 2 MHz wide band centered at 1420.405750 MHz, the rest frequency of the hydrogen line. The signal as a data stream (2 million samples per second) is fed into program RoenneSpectrometer (RSM), which performs the spectral analysis (with FFT = fast fourier transform), displays and stores the spectrum.

Observations with RoenneRadiometer (RRM)

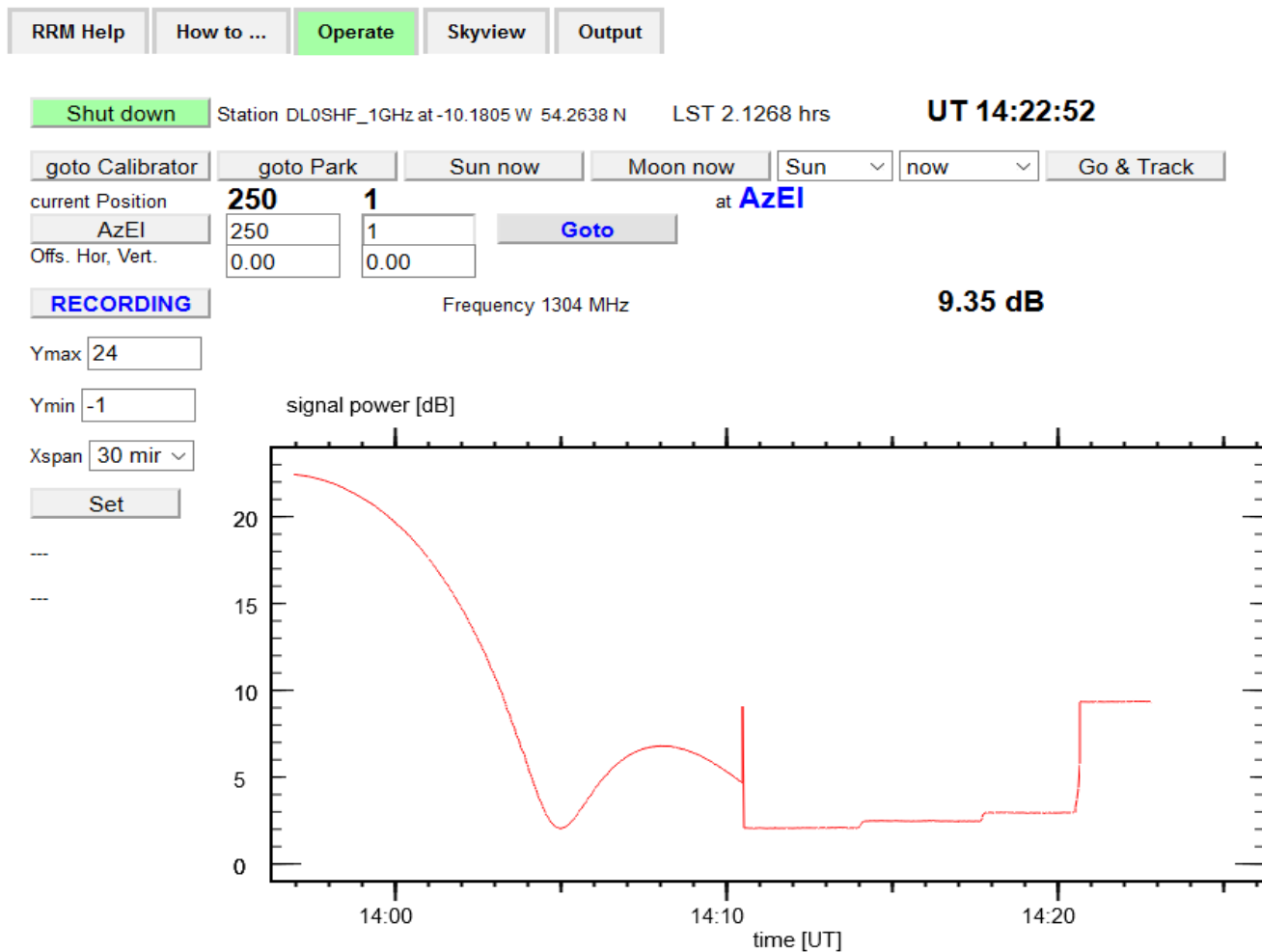

Fig.3: The 'Operate' page of RoenneRadiometer simulator (<http://www.astrophysik.uni-kiel.de/~koeppe/JS/RRM/RRM.html>), from which all necessary activities can be controlled and monitored. This shows an example of a drift scan of the Sun, followed by measurements of the 'empty' sky and a flux calibration by ground noise.

- The 'Operate' page contains all control elements to point the telescope, the display of the current position, and a plot of the data taken so far.
- The 'Skyview' page shows a view of the sky, with all currently visible objects.
- The 'RRM Help' pages contains a short description of all options.
- On the 'How to' page one finds some operational hints
- The observing session starts with 'Start up' and is terminated with 'Shut down'.
- When operating in real time, the data can be recorded with 'Record' ...
- The 'Output' page contains the stored observational data, which can be transferred with copy&paste to a text file!

Measurements with RoenneSpectrometer (RSM)

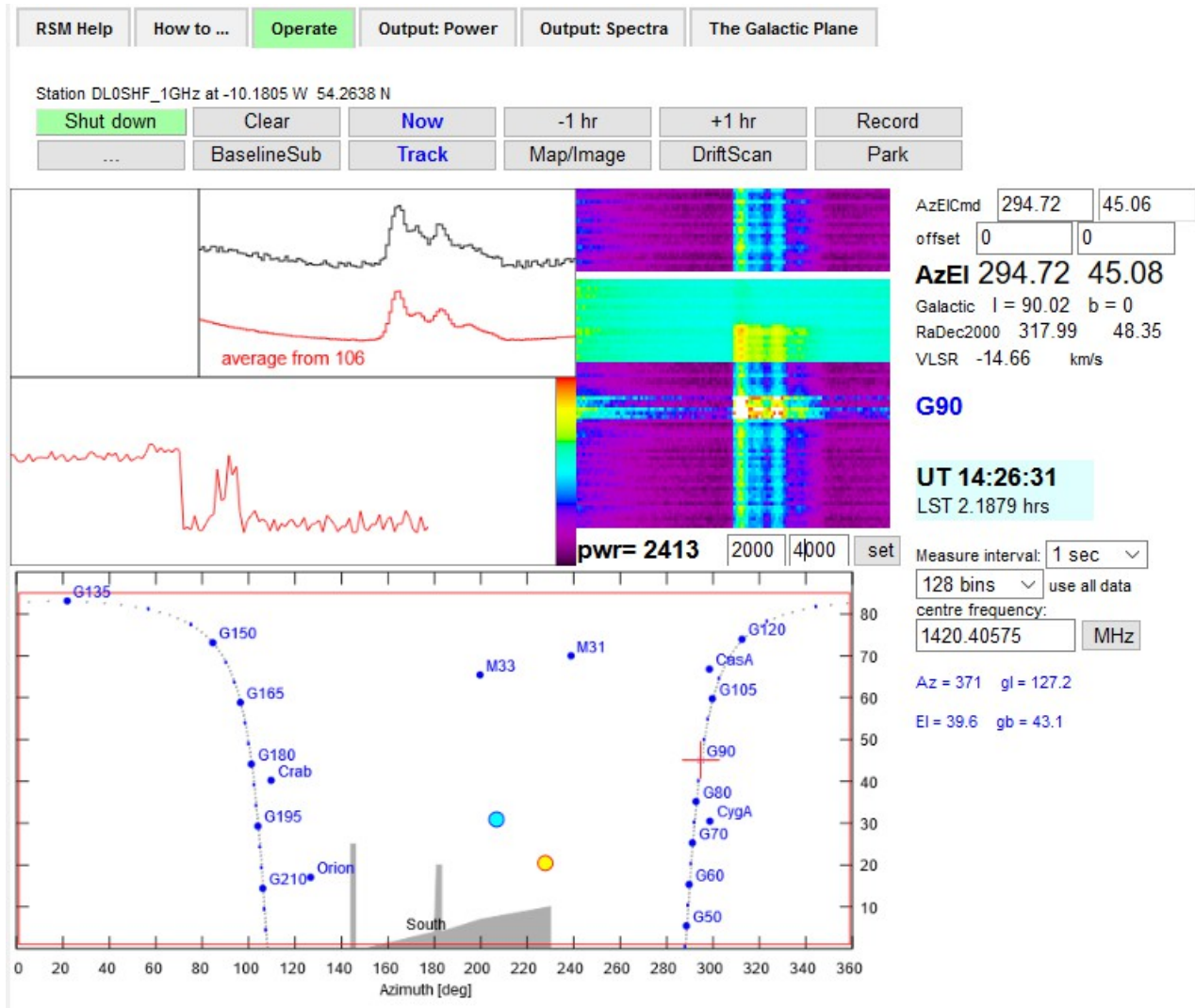

Fig.4: The graphical user interface of the simulator *RoenneSpectrometer* (<http://www.astrophysik.uni-kiel.de/~koeppe/JS/RSM/RSM.html>) shows a map of the sky with the currently visible radio sources, positions in the Galactic Plane (G... indicates their galactic longitude), and ground features (grey). The top centre contains a false colour map of the measured spectra in a waterfall display, to its left is a plot with the last spectrum (black) and the average over all previous spectra (red), and the time display of the received power. The panel at right displays all important numerical information and any messages. The program is controlled essentially via the graphical elements.

- The observing session is started by the button 'Start up' and is terminated with 'Shut down'.
- When operating in real time, the data can be recorded with 'Record' ...
- in 'Output: Power' one finds the power integrated over each spectrum
- in 'Output: Spectra' one finds the spectra from every instant
- The data may be copied from these pages into a text file using copy&paste.

Profile of the sky background

Basics

Radio radiation from astronomical objects is incoherent radiation in the continuum and in spectral lines, as the excitation (thermal excitation, synchrotron emission) involves many particles.

To this noisy signal comes the black body radiation at 2.7 K of the CMB, but foremost there is the noise from the receiver and the thermal emission of the Earth atmosphere, so that the measured signal is composed of several components, which need to be separated by suitable observational techniques.

- The object itself is characterized by its position and extent in the sky.
- The CMB radiation is the same everywhere in the sky.
- The receiver noise is independent of the position where the telescope points to.
- The Earth atmosphere which lies between any celestial object and the telescope adds its thermal noise to the signals from the object. Fortunately on 1 GHz the atmosphere is almost fully transparent, and thus the powers are simply added together.
- The foreground atmospheric noise depends on the elevation: Since the Earth atmosphere is just a very thin layer (8 km compared to Earth radius 6370 km), we can represent it by a plane-parallel model. The mass of air which is crossed by a line of sight at elevation ϵ is proportional to $1/\sin(\epsilon)$. Since the atmosphere is optically thin in the radio range, the emission is described by the simple expression $p(\epsilon) = p_{\text{zenith}} / \sin(\epsilon)$.

Note that on the line-of-sight from a celestial source this atmospheric emission is added 'last' before the radio waves reach the telescope. Thus, it might better be called a sky foreground rather than a background...

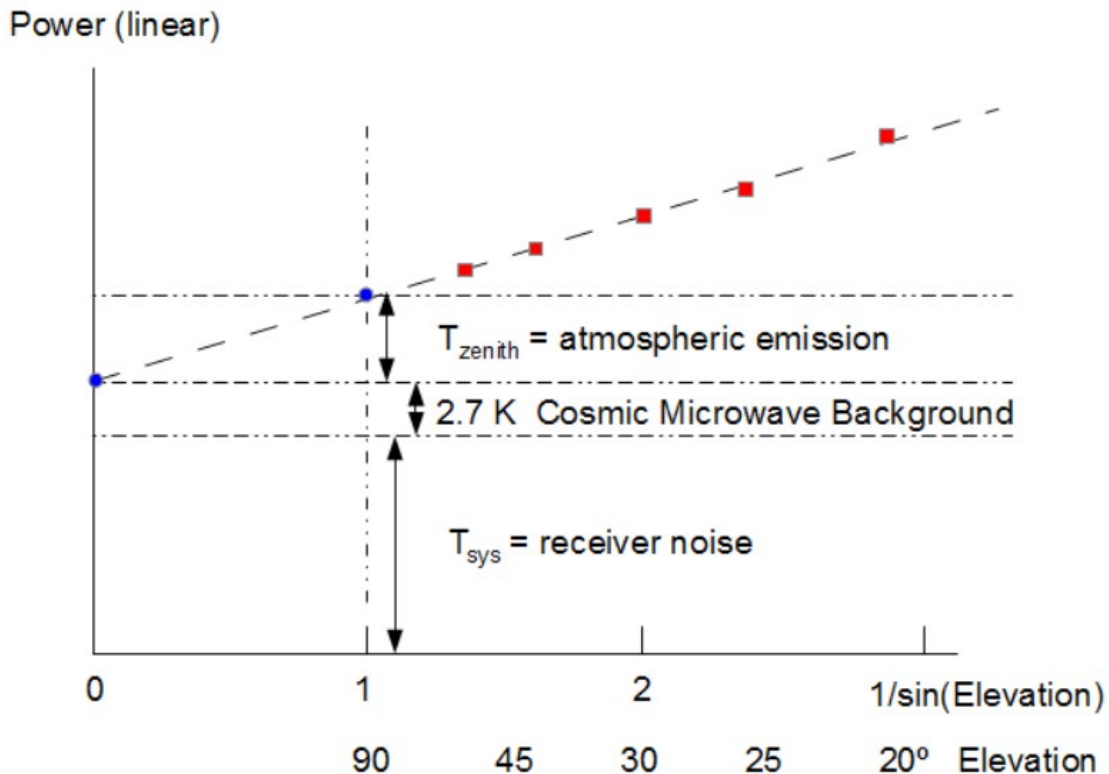

Fig.5: Dependence of the measured sky noise (red squares) on elevation. The different contributions are determined by extrapolation to the zenith and outside of the Earth atmosphere.

The noise from receiver, sky background, and CMB is always present when making a measurement of a source. Thus this must be subtracted. But we also need to know well the various components. They can be separated by measuring the profile of the sky background:

- Measure the noise of the 'empty sky' at several elevations.
- Match the data with a plane-parallel model.
- The derived linear relation between measured value and airmass= $1/\sin(\epsilon)$ is extrapolated to the zenith and to the (geometrically impossible) value $1/\sin(\epsilon) = 0$.
- From these values one determines all parameters.

In principle one should do such a measurement and analysis before (and may be also after) an observation. Fortunately on 1 GHz, the properties of the Earth atmosphere change only weakly. Furthermore, the receiving system is known to be quite stable, so that it often suffices to carry out this procedure only once a day. A different day may well find the sky and the receiver electronics in a different state ...

Observations

The sky noise is measured at an azimuth, which should be away from the Sun by more than 20° , to avoid that the radiation from this strong source enters the side lobes of the antenna (cf. Fig.8). A sequence of different elevations is measured. Since the background depends on $1/\sin(\epsilon)$, it is favourable to distribute the elevation in such a way that they are distributed roughly equidistant in $1/\sin(\epsilon)$. There is a need to measure above 70° , because near the zenith a parabolic dish antenna receives additional noise from the ground, which reaches the focus from beyond the rim of the dish ("spill-over"), as shown in Fig.6.

Do not forget to start recording at the start of the observations! Enter a new position in the fields next to **AzEl** and click **Goto** or hit the enter key. The antenna needs a bit of time (1 min pro 10° on the real telescope, the simulator is faster) to reach the new position. During slewing the current position is underlayed with a blue background. Since during the maneuver the motors may cause higher noise, one should accept the data only after the new position has been reached. At every position measure for a sufficiently long time, to get a well defined average value, but also to verify that the noise level stays really constant. Passing rain clouds – or the nearby Sun – could be the reason for any changes. Before and after the sky measurements one also measures the flux calibrator sufficiently long.

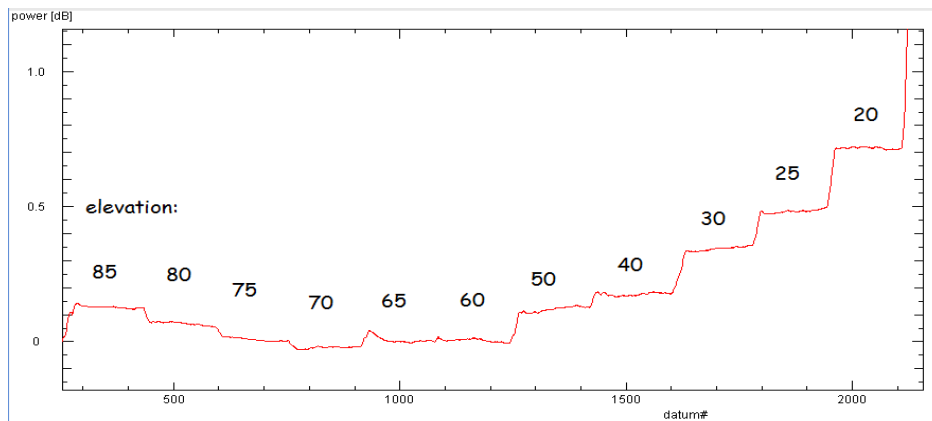

Fig.6: Plot of an observation of the sky background. The rise of the noise above 70° is caused by the 'spill-over' of the antenna. Note that sometimes (e.g. $65 \rightarrow 70^\circ$) there is enhanced noise during motion from one position to the next. The signal from the flux calibrator is 8dB, hence well outside the plot shown here.

Analysis

The data are stored in an ordinary text file, as a sequence of times (in UT), position in azimuth and elevation, horizontal and vertical offset angles (not relevant here) and the measured value in dB. It is quite convenient to do the data reduction with a spread sheet program (e.g. Excel). Development of even a small program often takes longer than one wants to ...

In Excel we execute these steps:

- import the file. Note that blank spaces are used as separators between values.
- for an overview, make a plot of the data as a function of time.
- as the measured values are given in the logarithmic unit (dB), convert them into linear power values: $p = 10.0^{(p_{dB}/10)}$
- by the elevations one identifies the positions.
- for each position compute the average value over all individual values. Avoid to include any perturbations, such as pulse type noise or motor noise during slewing.
- match a straight line to the data in the power vs. $1/\sin(\varepsilon)$ diagram.

From the parameters of the fit – slope m and y -offset b – we determine system temperature and the antenna temperature of the sky zenith: The measured power is given in some units which are determined by the apparatus and the software. To convert the powers p measured in a source to antenna temperatures, we need to know the conversion factor a :

$$p_{\text{source}} = a (T_{\text{source}} + T_{\text{sky}}(\varepsilon) + T_{\text{sys}} + T_{\text{CMB}})$$

which includes the contributions from the source, the sky background, the receiver noise, and the cosmic microwave background.

The measurement of the flux calibrator gives the signal level that corresponds to the physical temperature of the calibrator, because this source fills completely the antenna beam with its thermal radiation. Here we may use about 290 K for the temperature of the trees or the ground.

From Fig. 5 we see that the y -offset – which extrapolates the data to the value at $1/\sin(\varepsilon) = 0$, which would be a point outside the Earth atmosphere – is the sum of receiver noise and CMB:

$$b = a (T_{\text{sys}} + T_{\text{CMB}}) = p(1/\sin(\varepsilon) = 0)$$

When the telescope is pointed to the flux calibrator, there is no contribution from the sky and CMB:

$$p_{\text{cal}} = a (T_{\text{cal}} + T_{\text{sys}})$$

With the assumed value of $T_{\text{cal}}=290$ K these latter two equations give the conversion factor a and the system temperature.

Note that for a quick, rough first guess one may assume:

$$a \approx (p_{\text{cal}} - p(60^\circ)) / T_{\text{cal}} \quad \text{and} \quad T_{\text{sys}} \approx T_{\text{cal}} / (p_{\text{cal}} / p(60^\circ) - 1)$$

The slope of the fitting straight line is a measure of the emission of the Earth atmosphere. It is convenient to express it as the antenna temperature in the zenith:

$$T_{\text{zenith}} = m / a$$

The 1 GHz telescope has a system temperature of about 50 K. The zenith temperature is about 5 K on 1 GHz and appears to be quite independent of rain and sunshine. Furthermore, the system appears to be quite stable. Therefore, it is not absolutely necessary – at least for our purposes – to perform a time-consuming flux calibration before and after each observation.

It is quite recommendable to prepare before the actual observations in a spread sheet program such a page, where one can enter the measured values already during the observations, and do the fit and the analysis. In this way one gets a real time impression of the quality of the data, identifies any problems, and one can decide whether a repetition might be necessary.

Error considerations

For a thorough analysis of the errors for system and zenith temperatures it is necessary to identify all the possible uncertainties that are associated with the measured values. Ideally, the steps in the plot for the sky profile should be flat and horizontal, so that the values measured at an elevation should simply scatter about an average value. As Fig.6 shows, it may not only happen that the antenna motors produce some noise, but also that the signal level at the same elevation changes slowly, perhaps due to changes in the receiver electronics or the weather, e.g. by passing clouds. Furthermore there may be all kinds of weak or strong spikes from electric and electronic devices, radar emissions, and even birds flying through the antenna beam. A view out of the window can be quite helpful, although the telescope is outside Kiel. The averaging of values and the linear regression also give the statistical errors. Finally there could be an uncertainty about the assumption of a calibrator temperature of 290 K.

All these individual errors are to be quantified and their influence on the final results is to be shown. Which are the more important error sources, and at which measurement one has to be more careful, if this is possible ...?

Further considerations

1. Dependence on weather:

Measure the sky background under different sky conditions (blue sky ... dark rain clouds) and show how strongly the zenith temperature depends on the weather. The simulator does not treat the real weather, but realistic changes due to the receiver electronics are included. Thus, no two days are the same!

2. Absorption of the atmosphere:

It could be that we also use an antenna at a higher frequency, where the sky emission is stronger, in particular due to water vapour, which creates a stronger dependence on the weather.

Surface temperature of the Sun

Basics

The Sun radiates in the radio range a thermal continuum, which is the continuation of its optical and infrared spectrum towards longer wavelengths. As the opacity of the solar plasma increases with falling frequency, the radio continuum above 30 GHz is still produced in the photosphere, but at 10 GHz it comes from the lower part of the transition layer between chromosphere and corona, and for frequencies below 1 GHz from the corona. This layered structure together with the strong temperature rise to the corona produces the radio spectrum of the Sun (Fig.7):

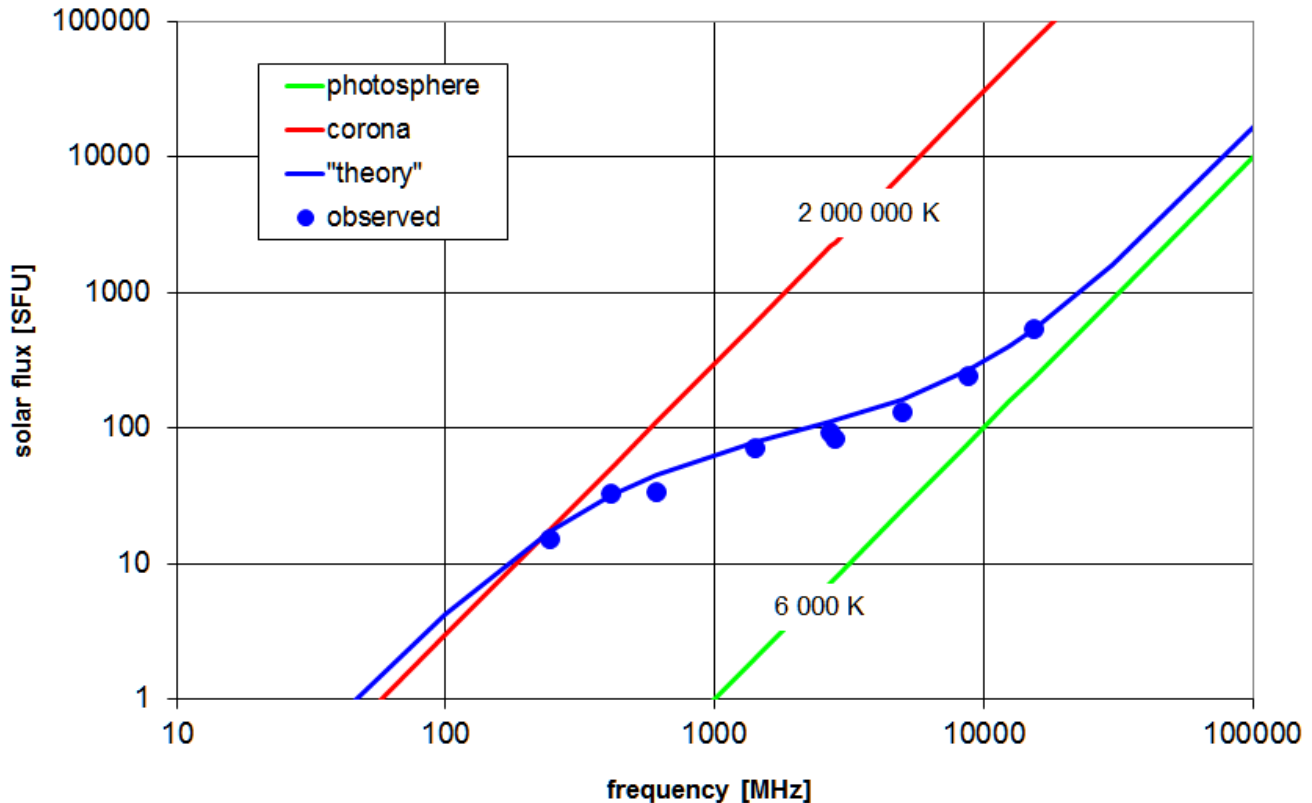

Fig.7: Spectral flux distribution of the Sun, which is monitored by a world-wide network of stations and published by NOAA (see Websites). For comparison blackbody spectra are depicted with photospheric and coronal temperatures.

The solar radio flux varies with the activity (sun spots, solar flares, ...) happening on the face of the Sun towards us. Solar activity and eruptions influence radio communications on Earth and with satellites. Therefore the radio Sun is continuously observed and its radio flux is measured.

The flux at 1.4 GHz gives information about the state of the lower layers in the corona, in particular about the temperature of these layers. Because an interpretation of the results requires an accurate knowledge of the system parameters, it is advantageous to observe the Sun with a drift scan: The telescope is pointed to a position which the Sun reaches about 10 min later. The telescope is left on this position, so that the Sun passes through the antenna beam, and hence is used also to measure the

sensitivity curve of the antenna beam. Measurements of the sky background (at the same elevation) and a flux calibration – before and/or after – complete the observations. In this manner we use the very precise rotation of the Earth to measure the antenna beam. Hence, this method can also be used with telescopes which do not have an accurate or stable positioning system.

Observations

Follow this procedure:

- start recording data.
- measure the sky profile and the flux calibrator sufficiently long to get an average value as accurate as needed (may also be done after passage of Sun – but: if the sky profile's steps are not nicely horizontal or if there are other indications that the noise level is varying, measure sky and calibrator both before and after the Sun's transit).
- choose Sun and +XX min as appropriate. Click Goto to move there. Make sure that tracking is off ...
- It may not be necessary to observe the entire passage, because the antenna has side lobes and the instrument is sensitive enough to measure them accurately in 15 oder 20° distance. It would take quite a while until one gets back to the 'empty' sky, but without getting any further essential information (such a long observation would be useful for a different project, the measurement of the antenna itself). As is obvious from Fig.8 it would suffice to get the top of the curve (down to 10 dB below the maximum value).
- measure the empty sky for an appropriate duration, at the same elevation, but at least 20..30° to the 'left'.

Figure 8 shows a drift scan, which includes the side lobes of the antenna:

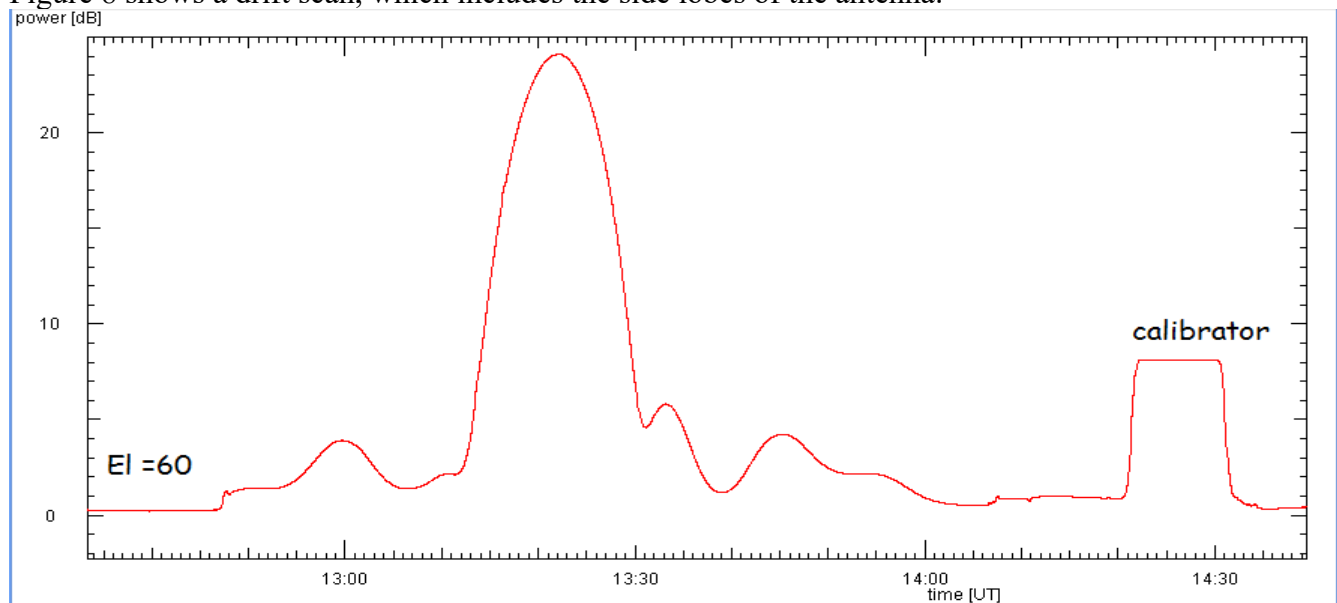

Fig.8: A drift scan of the Sun, with measurements of the sky background and the flux calibrator. The telescope was pointed to a position where the Sun would be 30 min later. During its passing through the antenna beam, the Sun also measures the angular dependance of the antenna beam sensitivity. Apart from the main lobe one notes several side lobes which are weaker by at least 20 dB, i.e. by a

factor of 100.

Analysis

This can also be done with spread sheet software:

- import the file.
- convert all dB values into linear power values.
- a plot of signal power versus time gives an overview of the data.
- identify measurements of calibrator, maximum of the Sun, empty sky
- compute averages for calibrator and empty sky: $p_{\text{cal}}, p_{\text{sky}}$
- compute system noise level: since $p_{\text{cal}} = a \cdot (T_{\text{cal}} + T_{\text{sys}})$
we get $p_{\text{sys}} = a \cdot T_{\text{sys}} = p_{\text{cal}} \cdot T_{\text{sys}} / (T_{\text{cal}} + T_{\text{sys}})$
- compute the antenna temperatures for all time points (and plot the curve...)
$$T_{\text{ant}}(t) = (p(t) - p_{\text{sky}}) / (p_{\text{cal}} - p_{\text{sys}}) \cdot 290 \text{ K}$$
- check also the level of the empty sky by comparing with the results from the sky profile task:
 $p_{\text{sky}} = ? = p(\epsilon) = \dots T_{\text{zen}} / \sin(\epsilon)$ with e.g. $T_{\text{zen}} = 5 \text{ K}$
- determine the times of maximum solar signal and the two time points when the power is at half maximum power. This gives the Half Power Beam Width of the antenna:
$$\text{HPBW} = (t(-1/2) - t(+1/2)) \cdot 15^\circ/\text{h} \cdot \cos(\text{declination}_{\text{sun}})$$

The last factor takes into account that the angular velocity of the Sun at its actual distance from the celestial equator is less than $360^\circ/24 \text{ h}$.
Why do we use here $15^\circ/\text{h}$ instead of $360^\circ/\text{sidereal day} = 15.04107^\circ/\text{h}$?
- Alternatively, one may fit a gaussian profile to the $T_{\text{ant}}(t)$ curve. Note that $\text{FWHM} = \text{HPBW} = 2.3548 \sigma$, and don't forget the correction for solar declination.
- This determination of the antenna's HPBW assumes that the observed object is a point source. The Sun is a disc of fairly uniform brightness with an angular diameter of about 0.5° . Therefore the measured profile is somewhat broader. Check with the JavaScript tool <http://www.astrophysik.uni-kiel.de/~koeppen/JS/Blurring.html> by how much this affects the determination of the true HPBW.

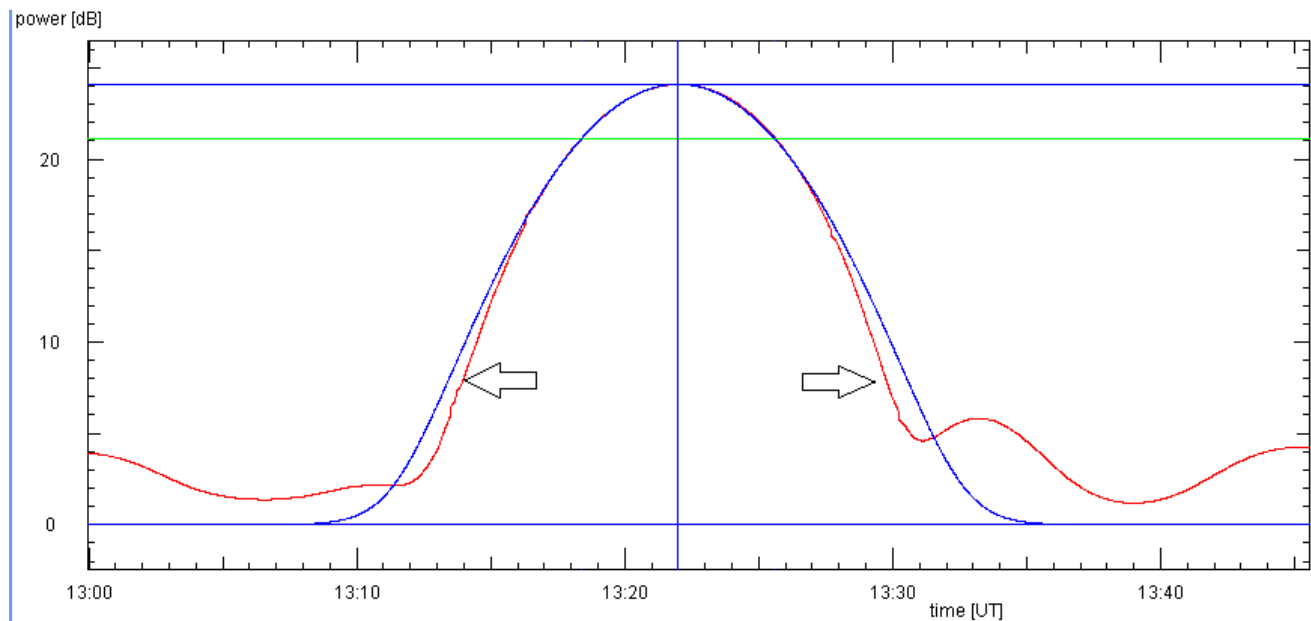

Fig.9: Example of matching a gaussian profile (blue) to the data of the drift scan. Horizontal blue lines mark the maximum value and the sky background. The green line indicates the level of the half (linear!) power difference between maximum and background, and hence the HPBW. Note that in its lower parts the observed profile is narrower than the gaussian. Since for the determination of the HPBW the lower part and the side lobes are not necessary, a drift scan may well be restricted to the range indicated by the arrows, i.e. to about 20 min. But be sure to measure the sky noise at the same elevation!

Declination and angular diameter of the Sun can be obtained from the skript <http://www.astrophysik.uni-kiel/~koeppen/JS/SunMoon.html>.

Since the angular diameter of the Sun is smaller than the HPBW of the antenna, the Sun can only fill a small portion of the antenna beam. Therefore the maximum antenna temperature is smaller than the true (physical) temperature of the Sun. This is approximately the ratio of the solid angles of Sun and antenna beam. If one estimates this filling factor very roughly with the assumption that both Sun and antenna beam have rectangular profiles, one gets for the temperature in the layer of the Sun that produces the radio radiation:

$$T_{\text{sun}} = \dots \max(T_{\text{ant}}) * (\text{HPBW} / \text{Ang.Diameter}_{\text{Sun}})^2$$

If we take into account that the antenna beam has a more realistic profile, we get a very similar form:

$$T_{\text{sun}} = \max(T_{\text{ant}}) * \Omega_A / \Omega_{\text{sun}} = \dots \max(T_{\text{ant}}) * (\text{HPBW} / \text{Ang.Diameter}_{\text{Sun}})^2$$

with a factor of proportionality that you should work out from the basic equations on pages 4 and 5. This approximation is only valid as long as the radio source is much smaller than the antenna beam. For the Sun (and Moon) this is no longer true, so one has to compute the filling factor by a convolution of the brightness profile with the shape of the antenna lobe. This can be done with the script <http://www.astrophysik.uni-kiel.de/~koeppen/JS/Blurring.html> . Here one may also check how good is the assumption that the Sun is treated as a point source.

Error considerations

Identify and quantify all error sources and uncertainties. What is the overall error bar on the temperature? Which measurement is the most critical one?

Further objectives

1. Angular resolution (HPBW):

The mirror is illuminated by the feed antenna in its focus, if one operates the antenna in transmission. Thus, the geometrical surface is not illuminated in a uniformly manner. If one applies Rayleigh's criterion, what would be the HPBW of our dish with diameter of 9 m? The measurement of the HPBW permits us to determine the 'effective' diameter, which is the diameter of the illuminated part of the dish. The aperture efficiency is the ratio of effective and geometric area.

2. Solar radio flux:

As the results of daily measurements of radio fluxes are available from NOAA, we may compare them with our measured radio flux.

From the solar antenna temperature T_{ant} and the knowledge of the effective area of the 1 GHz mirror of about $A_{\text{eff}} = 40 \text{ m}^2$ we can compute the radio flux F . The data from NOAA (<http://www.swpc.noaa.gov/ftpmenu/lists/radio.html>) are given in Solar Flux Units: $1 \text{ SFU} = 10^4 \text{ Jy}$. Radio fluxes are daily measured at several frequencies between 245 MHz and 15.4 GHz. It takes a few hours before the latest data are published on the internet. The fluxes show aside from short-term variations also a slower, systematic dependence due to the solar rotation which shows different surface regions at different times.

Since for the interpretation we need to know the properties of our antenna, one can also use the comparison with the NOAA data to determine the parameters of our antenna, e.g. the effective area A_{eff} and the efficiency.

Surface temperature of the Moon

Basics

The lunar surface is heated by the solar radiation and emits thermal radiation in the infrared and radio range. Already in 1949, Piddington and Minnitt showed that the radio flux from the Moon varies with the lunar phase. The temperature, averaged over the lunar face, is highest not at Full Moon, as one might have guessed, but about 4 or 5 days later. This time delay revealed (long before the human lunar landings) that the surface of the Moon is composed not of solid rock, but that it is made from broken-up material, such as dust and small pebbles. Because of the smaller thermal contact between the solid particles the layers below the immediate surface heat up only slowly. This temperature variation has been shown to be detectable by conventional satellite TV receiver equipment (Monstein, 2001).

Observations

One proceeds very much as with the Sun:

- start data recording
- skyprofile and flux calibration, sufficiently long to get an average value as accurate as desired (you may do this before or after the lunar transit – but: if the sky profile's steps are not nicely horizontal or if there are other indications that the noise level is varying, measure sky and calibrator both before and after)
- select Moon and +XX min as suitable, click Goto to get there. Make sure that tracking is off ...
- It is possible to cover the entire transit. It is recommended to wait until the signal level of the empty sky is reached again and also remains constant.
- Before and after the transit there will be a part of constant level from the sky background. It is recommendable to record the signal for some more time, to verify that the empty sky level remains (hopefully) constant.

Such a drift scan is shown in Fig.10:

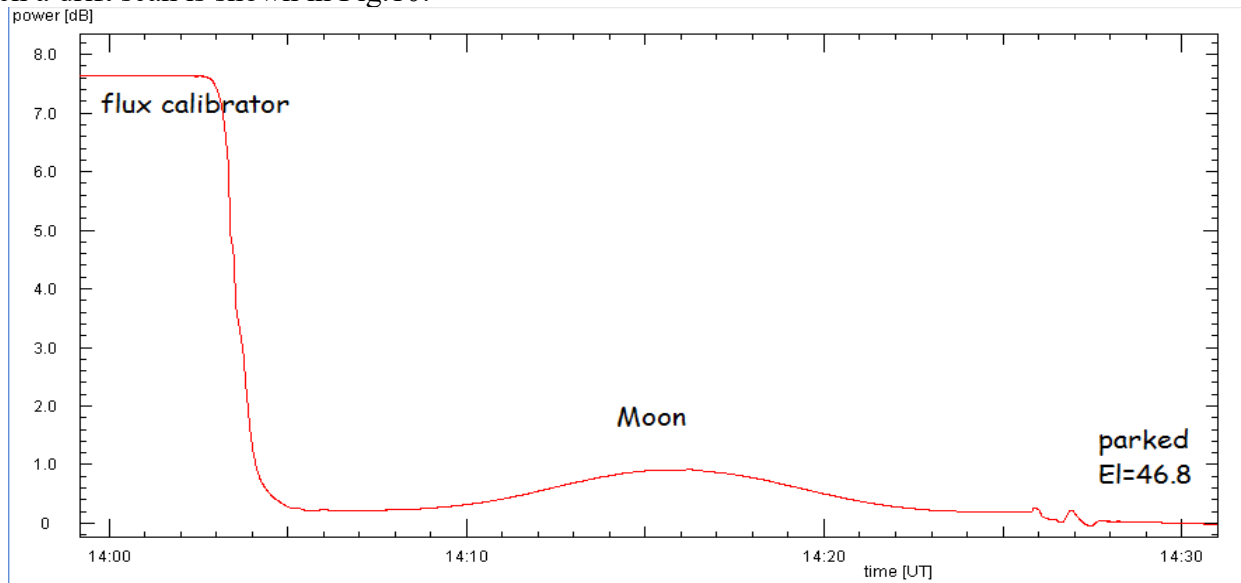

Fig.10: Drift scan of the Moon, 4 days after New Moon. The transit is preceded by a flux calibration and followed by the measurement of the empty sky at park position. Note the empty sky noise just before and after the lunar transit.

Analysis

Reduction and interpretation of the data is done in the same way as described for the Sun. One may leave out the determination of the antenna HPBW... but as the data are pretty good, it is worth to check whether one arrives at the same values!

Since the lunar signal is just a bit above the sky background, it is important to have an accurate measurement of the latter level in order to do a reliable subtraction of the background. If the measured background differs from the value which one computes from the measurements of the sky profile, this may indicate changes in the receiving system or the weather. How can one decide this?

Further objectives

1. If the measured background differs from the predicted one ...

Although the observing conditions on 1 GHz normally are quite independent of the weather, it may well happen that the measured level of the empty sky differs from the predictions on the basis of the sky profile. One should not blindly assume that the fit is valid for all times! Depending on the desired accuracy a temporal change of the weather or the density of terrestrial clouds could well have noticeable consequences. Therefore it is best to check these values.

In order to be well prepared to any possible problems, it is recommendable to measure after a drift scan not only the sky noise at the same elevation, but also at some other elevations (perhaps 5 or 10° lower or higher). Then it is possible to determine a partial sky profile for the moment of observation, without making a tedious full measurement. Please be aware that if you find during the analysis that there is some problem with the sky noise, it is no longer possible to make a missing measurement, and your only option is repeat the entire observation!

If we have a flux calibration, measures of the source and the empty sky at elevation ϵ_1 , and also the sky at another elevation ϵ_2 , we can use the three equations

$$p_{cal} = a (T_{sys} + T_{cal})$$

$$p_{sky1} = a (T_{sys} + T_{CMB} + T_{zen}/\sin(\epsilon_1))$$

$$p_{sky2} = a (T_{sys} + T_{CMB} + T_{zen}/\sin(\epsilon_2))$$

to derive uniquely all three unknowns: a , T_{sys} and T_{zen} . Then we compute the antenna temperature of the source from:

$$p_{source} = a (T_{sys} + T_{CMB} + T_{zen}/\sin(\epsilon_1) + T_{source})$$

2. Monthly variation of the radio flux

Just as with the Sun, we can compute the lunar radio flux. Since the Moon is too small to fill the antenna beam, the measured power depends on the flux and therefore on the distance to the Moon, which varies during one month:

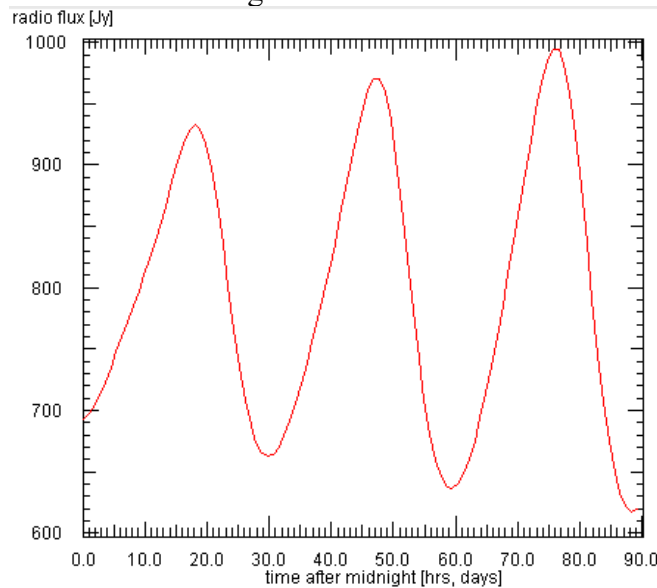

Fig.11: Predicted radio flux of the Moon for the first 90 days of 2015. Since the beam of the 1 GHz antenna is larger than the lunar angular diameter, one measures essentially the radio flux, which varies with the actual distance.

3. Monthly variation of the surface temperature

Moon Surface Temperature @ 2.77cm

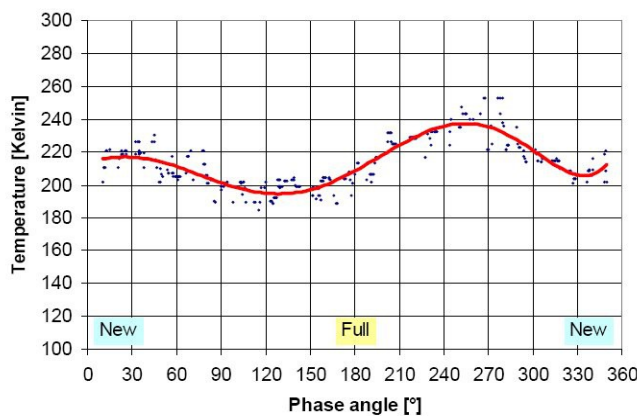

Fig.12: The temperature averaged of the lunar face varies with the lunar phase. These are results from measurements with a satellite-TV equipment on 10 GHz (Monstein, 2001).

One may also use the fit by Piddington and Minnitt (1949):

$$T_{moon} = 239 \text{ K} + 40.3 \text{ K} * \cos(\text{phaseAngle}+225^\circ)$$

Radio fluxes from other celestial sources

Basics

Apart from the Moon it is possible to observe at 1300 MHz a few more radio sources, such as the supernova remnant Cas A, the radio galaxies Cyg A and M87, as well as the Quasar 3C273. They can be observed with a drift scan. All these objects are fairly faint sources. Therefore it is very important to carefully measure and check the sky background (cf Point 1 of the Moon). These sources have non-thermal spectra (synchrotron emission), for which a derivation of the temperature makes no sense. However, one can compute the radio flux, and compare it with values from the literature. Since all are point sources, the obtained curve reveals the true shape of the antenna beam – does it agree with the solar observations?

Rotation curve of the Milky Way

Basics

The Solar System is a small object which participates in the rotation of the Galactic Disc around the centre. We are at a distance of about $R_{\odot} = 8.5$ kpc from the centre, approximately on a circular orbit with a speed of about $v_{\odot} = 210$ km/s. With the line of the hyperfine transition of the hydrogen atom at 1420.405750 MHz – corresponding to a wavelength of about 21 cm – we can observe clouds of neutral gas everywhere in our Galaxy (optically thin!), and measure the radial velocity with the line's Doppler shift. Thus, is it not only possible to map the interstellar neutral gas of the galactic disc but also to determine the rotation of the disc:

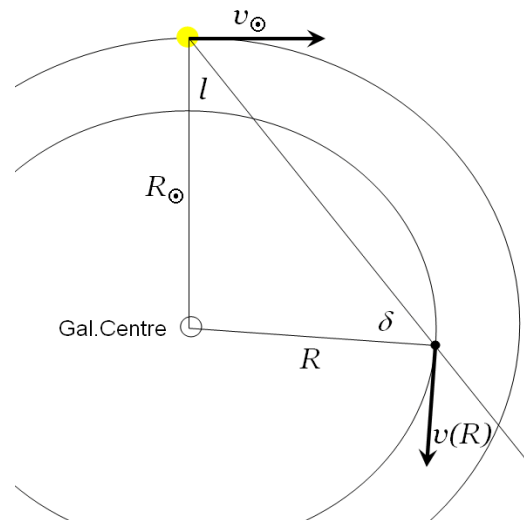

Fig.13: *Geometry of the observation of a hydrogen cloud in the galactic disc*

Figure 13 shows the observation of a gas cloud seen at galactic longitude l and on a circular orbit with radius R about the centre and with velocity $v(R)$. With the sine-law of triangles, we compute the radial velocity at which we would measure this emission as:

$$V_{rad} = (v(R) * R_{\odot}/R - v_{\odot}) * \sin l$$

The measured spectrum is the superposition of the emissions from all clouds on this line of sight. Since the interstellar gas is concentrated in spiral arms, these show up as stronger features.

For the lines of sight which cross the inner part of the solar orbit, i.e. $0^{\circ} < l < 90^{\circ}$ and $270^{\circ} < l < 360^{\circ}$, there is a very useful particularity: the measured radial velocities have a maximum value. This is the emission from clouds that lie on the circle for which the line of sight forms the tangent. Convince yourself of this fact with the above formula, or by visualisation from the Script <http://www.astrophysik.uni.kiel.de/~koeppen/JS/MWGrotation/index.html> .

With this trick we can determine from the maximum radial velocity v_{max} at galactic longitude l the rotational speed for the radius $R = R_{\odot} \sin l$:

$$v(R) = v_{max} + v_{\odot} * \sin l$$

Please note that this method works only in the first and the fourth quadrant, because on all other lines-of-sight the radial velocity is a monotonic function of the distance from the Sun. On those other lines of sight, we must obtain the information of the distance in some other way! For us on the northern hemisphere of the Earth this also means that only observations in the first quadrant are suitable to determine the rotation curve of the Milky Way.

Observations

Use the simulator or the scheduling tool to choose the time of observations so that the positions G20...G90 – i.e. the first quadrant – are above the horizon. Then the observations are simple:

- Choose the number of frequency bins of the spectrum (128 are completely sufficient; more points give a finer resolution than is really necessary. It looks nicer, but makes more work)
- Set the frequency: 1420.405750
- Record: don't forget to start the recording ;-)
- on the sky map of RSM click on a position G20...G90, so that antenna goes there and tracks this position automatically ('Track' appears in blue)
- measure each position as long as needed for the desired signal-to-noise ratio.
- already after a couple of spectra you will see that the red curve (= the averaged spectrum) becomes sufficiently noise-free or that the waterfall display shows a stable structure:
 - **perform a quick analysis:**
 - click on the left end of the emission profile, where it merges into the flat background – or click on the corresponding position in the waterfall ...
 - this gives a display of the maximum radial velocity (this is already corrected for the motions of Earth and Sun relative to the Local Standard of Rest (LSR) which is the theoretical inertial system at the place of the Sun)
 - compute the rotational speed (as above)

- do this for all galactic longitudes up to 90°
- note that $l=90^\circ$ gives no direct information, but ... (see Point 2 below).
- To measure below $l=20^\circ$ is somewhat difficult, as this will be quite low above the horizon so that we pick up more noise from ground radiation. But also the galactic emission at high velocities is rather weak, because the inner 3 kpc contain only little neutral gas (but see also Point 4 below).

Figure 12 shows how a spectrum with 512 bins looks like after 5 min of observation:

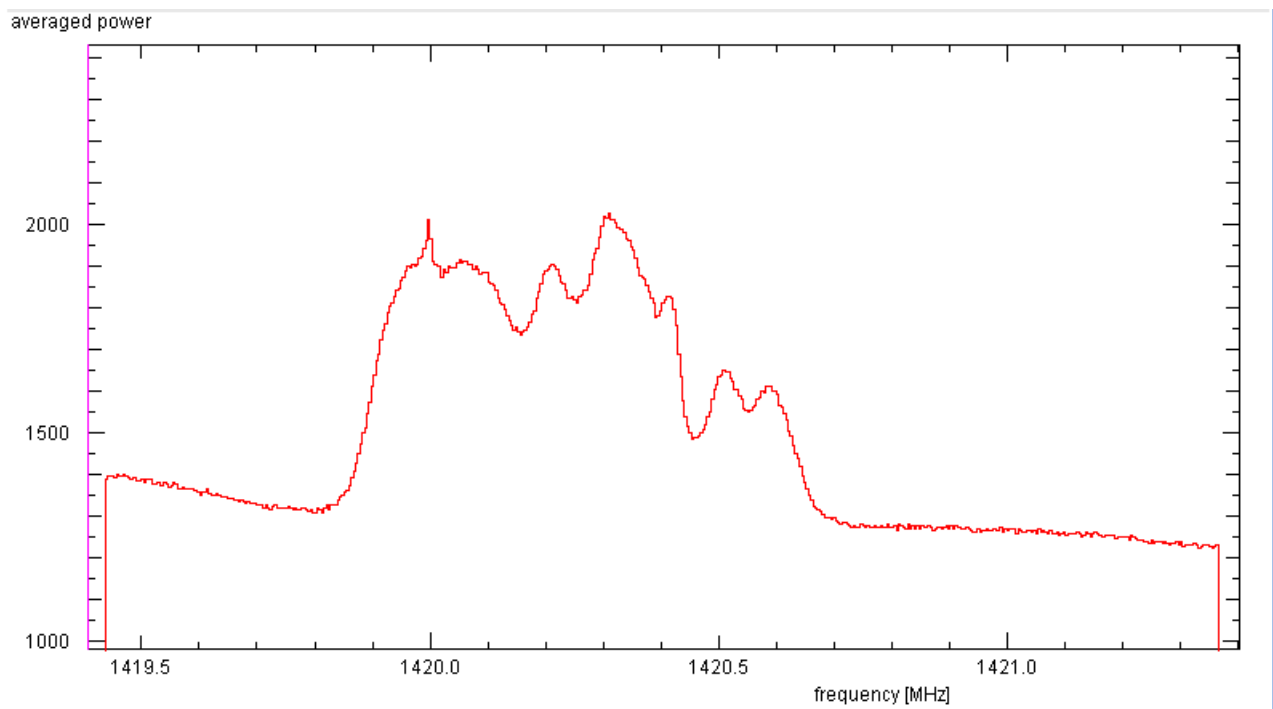

Fig.14: *The average spectrum of raw data of the Milky Way at $l=30^\circ$ $b=0^\circ$ taken with the (real) 9m antenna at Rönne. The sharp peak at 1420.0 MHz is a terrestrial interference, most probably from the local electronics. On either side of the line emission from the Milky Way there is the smooth level of the receiver noise, with a small contribution from the galactic continuum (thermal and synchrotron emission).*

Analysis

The data are in the form of a text file. Each text line contains a spectrum, together with the time, position (azimuth and elevation), positional offsets (does not apply here), the correction term VLSR of the radial velocity for the LSR, number of frequency bins, frequency of the first bin (in MHz), the step width (in MHz), followed by the data of all bins of the spectrum.

Comment lines start with an asterisk and give information about commands from the user, such as the source to which the telescope is ordered to move.

The analysis is best done with a spreadsheets program (Fig.15 shows an example in Excel with a file with a slightly different format):

- import the file
- perform these operations for all positions:
 - identify the pieces of data associated with this position
 - ignore data taken during the slewing of the antenna to the next position
 - for every frequency bin: compute average values of all these spectra and store them in a prepared line
 - convert the frequencies into radial velocities, with the correction for LSR

$$v_{\text{rad}} = -\text{VLSR} - (f/1420.405750\text{MHz} - 1) * 299792.5 \text{ km/s}$$
- make a x-y plot of this average spectrum:

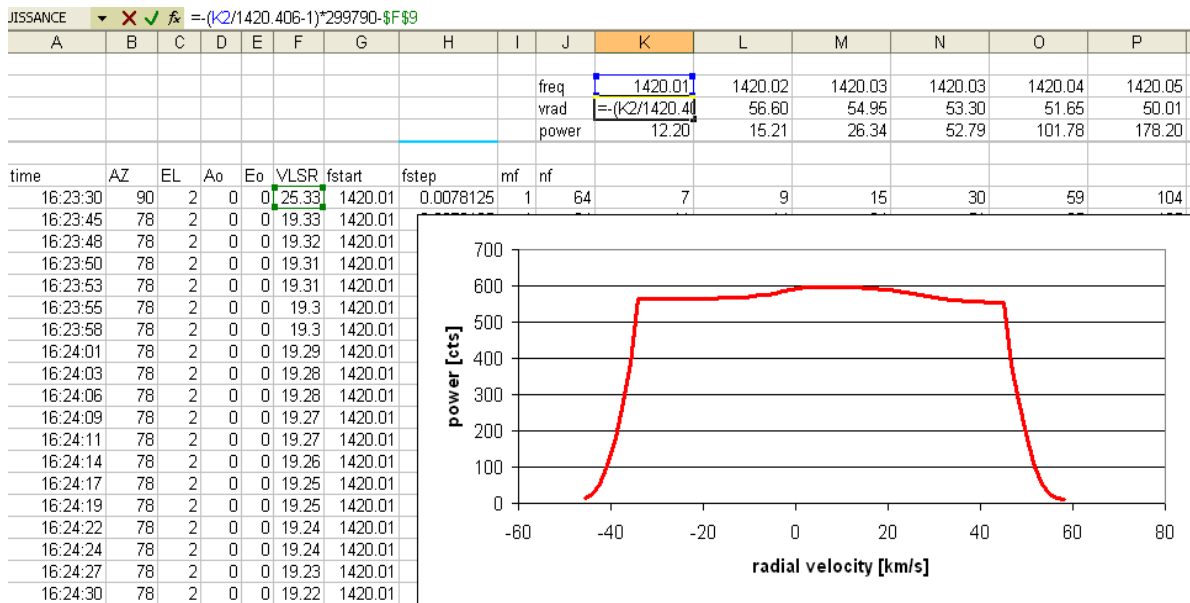

Fig.15: Example of a data reduction with Excel: Generate a plot of the averaged signal values as a function of radial velocity

Because we are only interested in the hydrogen line emission in the middle of the spectrum, the 'empty' parts left and right of the galactic components represent only background noise. This is the sum of noise from receiver, Earth atmosphere, CMB, and continuum emission of the Milky Way. Over the small frequency span shown here, they all have a constant intensity. To separate the line emission from this background, we approximate it with a suitable frequency-dependent function, called 'baseline'. The difference of the averaged raw spectrum and the baseline is the reduced spectrum of the line emission.

Figure 16 shows the use of a constant (blue curve) and a linear baseline (red). The linear baseline is defined by the measured values at two anchor points. With a plot of the spectrum after subtraction of the baseline one watches the action of manually changing the parameters for the baseline. One aims to bring the left and right ends of the spectrum close to zero. Similarly, one can handle other types of baseline functions. It is best to use a polynomial function of lowest order which makes the background sections of both ends of the area of interest go as flat and as close to zero as possible (Fig.16).

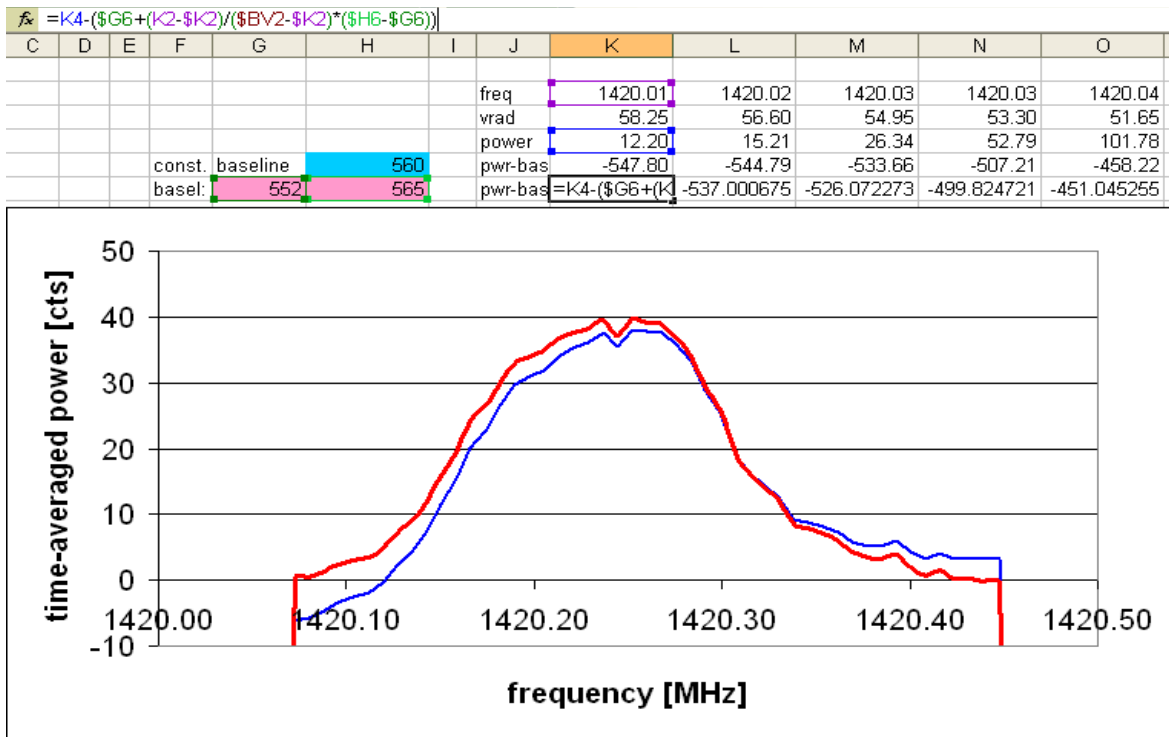

Fig.16: Example of the matching of a linear baseline: by choosing suitable ordinate values at two anchor points near the spectrum ends one can bring the emission-free parts of the reduced spectrum (red) close to zero. Because of the rather narrow frequency range of this dataset one can only bring the end points to zero. The blue curve is obtained with a constant baseline, which reduces the background only in the middle of the spectrum.

At each of these reduced spectra from the individual positions we now determine the maximum radial speed in some way, and then the rotational speed at the corresponding distances from the Galactic Centre, i.e. the rotation curve of the Milky Way.

Which criterion shall we use to determine the maximum radial velocity? In whatever way you do this, apply it in the same way at all positions. A consistency check is possible at $l=90^\circ$ (see Point 2 below). Do not demand too high a precision, because the data themselves show that the structures in the spectrum, which come from cloud complexes and spiral arms, have widths of several km/s.

We may go a step further and calibrate the spectra in terms of antenna temperature: The baseline is the sum of the noise from receiver, Earth atmosphere, CMB (whose temperature is known), and some contribution from the continuum radiation of the Milky Way. Since the receiver noise usually is the largest contribution, we may approximate the antenna temperature of the baseline by setting it equal to the system temperature. Thus we obtain for the overall data reduction at each frequency:

$$T_{\text{ant}}(f) = (p(f) - p_{\text{Baseline}}(f)) * T_{\text{sys}} / p_{\text{Baseline}}(f)$$

with the raw measured value $p(f)$, the value of the baseline $p_{\text{Baseline}}(f)$ and T_{sys} . Since the spectroscopy is

done with a different section of the receiver chain, the system temperature must not be the same as in the radiometric measurements. An approximate value is 110 K from earlier measurements. You may well perform a complete flux calibration (cf. Point 6 below). Then one gets a completely reduced and calibrated spectrum (Fig. 17):

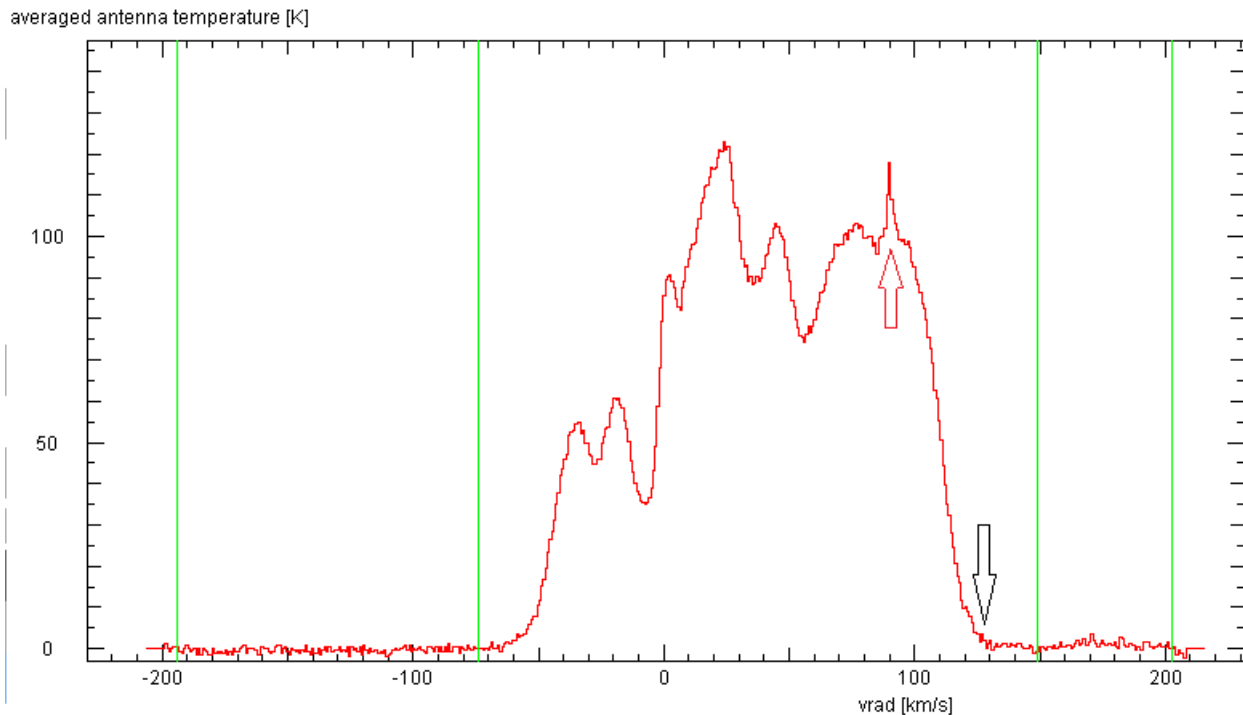

Fig.17: *The fully reduced and calibrated spectrum of the HI emission of the Milky Way at $l=30^\circ$ $b=0^\circ$. The abscissa is the radial velocity with respect to the Local Standard of Rest. The ordinate is a provisional calibration, based on the assumption of a system temperature of 50 K. Green lines mark the anchor points to fit a cubic baseline to the background. A red arrow points to a interference signal at 1420.0 MHz, the black arrow points at the maximum radial velocity.*

Error considerations ...

Further objectives

1. Assumption of circular orbits

How good is the assumption that all matter in the disc is on circular orbits? We may check this directly by measuring at $l=180^\circ$: In this direction all gas clouds that are on circular orbits would have no radial velocity component as seen from the Sun. Thus, we should observe a radial velocity = 0 km/s, for all clouds, independent of their distance. What we observe in reality is a narrow line, whose width is determined by the randomly distributed proper motions of the clouds, i.e. the deviations from the circular speed. Measure the line width and determine the velocity dispersion which gives an upper limit for the deviations from circular orbits.

2. Rotational speed at $l=90^\circ$:

How do we determine the maximum radial velocity? If we use the frequency point right at the point where the line emission rises above the background noise, we may systematically overestimate the maximum speed. This can be seen for the spectrum at $l=90^\circ$: from the formula we get

$$v(R = R_\theta) = v_{max} + v_\odot * \sin 90^\circ = v_{max} + v_\odot$$

which should be equal to the rotation speed at the location of the Sun, which we had assumed to be

$$v(R_\theta) = v_\odot$$

This means that we should rather use a point in the spectra, which gives at $l = 90^\circ$ a radial velocity of 0 km/s. How shall we do it?

3. Comparison with a mass model for the Milky Way

The obtained rotation curve can be compared with the expectations from a (here: simplified) model of the distribution of mass in the Galaxy: The speed for a circular orbit with radius R is computed from the total mass $M(R)$ which is inside a sphere of this radius

$$v(R) = \sqrt{R * g(R)} = \sqrt{G * M(R) / R}$$

with the gravitational constant $G = 6.67259 \cdot 10^{-11} \text{ m}^3\text{kg}^{-1}\text{s}^{-2}$.

The visible mass of the Milky Way is composed of old stars in the Galactic Bulge and stars of various ages as well as interstellar matter in the Disc, and old stars and globular clusters in the Halo. The Bulge we may model with the (volume) density of a Plummer sphere:

$$\rho(r) = 3 M / (4\pi a^3) * (1 + (r/a)^2)^{-5/2}$$

with a total mass of $1.3 \cdot 10^{10} M_\odot$ and the size parameter $a = 0.4 \text{ kpc}$.

The visible spherical Halo (field stars and globular clusters) is strongly concentrated to the centre:

$$\rho(r) \sim (a + r)^{-3.1}$$

with total mass $M = 4 \cdot 10^9 M_\odot$ within about 50 kpc from the centre, and $a = 0.5 \text{ kpc}$. It is only of minor importance.

The Disc can roughly be represented by an exponentially decreasing surface density:

$$\Sigma(r) = M / (2\pi a^2) * \exp(-r/a)$$

with a mass of $10^{11} M_\odot$ and the radial scale length $a = 4 \text{ kpc}$.

The mass inside a sphere of radius R then is computed from the density distributions by numerical integration. This can also be done with spread sheet software by using the simple Riemann sum with a suitably small step width Δr

$$M(R) = \sum (4\pi r^2 \rho(r) + 2\pi r \Sigma(r) + \dots)\Delta r$$

The sum goes from $r = 0$ to $r = R$. The first term sums over the volume density for Bulge and Halo, the second term over the surface density of the Disc.

You will find – as in all spiral galaxies – that the measured rotation curve cannot be explained by the visible mass. This led to the postulate of the presence of a spherical distribution of 'Dark Matter'.

Model this dark halo with another Plummer sphere. How much mass M and what size parameter a are necessary to reproduce the measured rotation curve? What are the ranges for these values to give reasonable fits of the data?

Important hints:

- When modelling the rotation curve, you should assume that the rotation speed outside the solar orbit ($r > R_{\odot}$) remains constant, which it is known from other observations. What happens if the speed were perfectly constant up to a radius of 20 kpc?
- It is also known that in spiral galaxies the dark halo is significantly larger than the galaxy itself. Since the density in a Plummer sphere drops gently outwards, it is necessary to consider a large volume of about 50 kpc radius to determine the total mass of the dark matter. The contribution of dark matter inside the solar orbit is quite unimportant.

So far, there has not been any experimental confirmation of the existence of elementary particles which interact with other matter only by gravitation. Thus, we cannot exclude alternative explanations, such as deviations from Newton's law of gravitation ... (cf. <http://www.astrophysik.uni-kiel.de/~koeppen/Haystack/docs/GalacticRotation.pdf>) ... you might try to work out the rotation curve based in the idea of MOND (Modified Newtonian Dynamics).

4. Rotation curve close to the Galactic Centre:

The gaseous disc of our Galaxy has a hole in its centre; within a radius of about 3 kpc the density of neutral hydrogen is much lower than in the other parts of the disc. This results in a lower emission at high radial velocities for longitudes below about 25° . This fainter emission is detectable with our telescope only for longer observation times. Furthermore, in Kiel the innermost part of the Galaxy remains rather close to the horizon, so that we have enhanced noise from ground radiation. It is not yet clear, whether it is possible to measure this weak galactic emission with the 9m dish. It would be worth trying to observe the inner 20° in galactic longitude ...

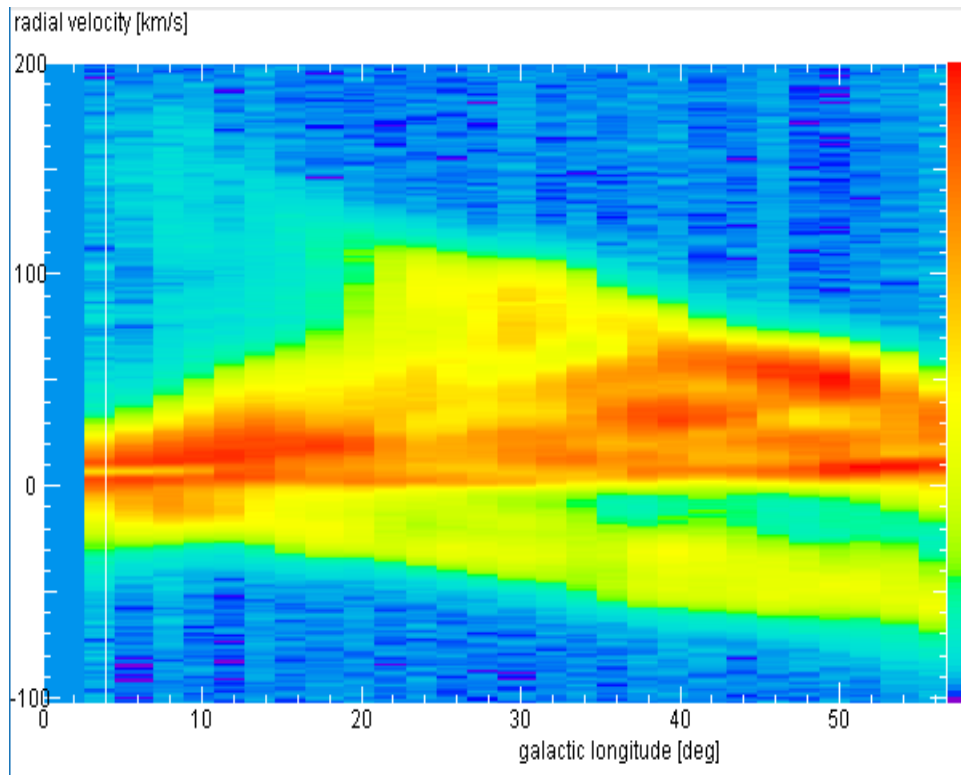

Fig.18: False colour map of the spectra of the HI emission in the Galactic Plane, up to $l=60^\circ$. The spectral intensity is coded with the colour bar at right, from 0 to 65 K. The weak emission at high radial velocities below $l=25^\circ$ comes from the low-density part of the innermost 3 kpc. These are data from a 4m diameter telescope by J.-J.Maintoux (F1EHN at <http://www.flehn.org>).

5. Mapping of spiral arms

The bumps in the spectrum from one position can be found in the spectrum of the neighbouring positions. If one performs systematic observations in the Galactic Plane with a step of 5° in galactic longitude and represents the data with a false colour map, it is easy to trace the spiral arms in the Plane ...

6. Flux calibration of the spectra:

In the same way as for the calibration of the radiometry we measure spectra from the flux calibrator and from several positions in the 'empty' sky at different elevations, each being several minutes long. The system temperature then can be obtained as a function of frequency (Fig. 19) by applying to each frequency point the formulae from the radiometric measurements of the sky profile. If we neglect the emission of the Earth atmosphere, we get approximately:

$$T_{\text{sys}}(f) = (T_{\text{cal}} - (P_{\text{cal}}(f)/P_{\text{sky}}(f))T_{\text{CMB}}) / (P_{\text{cal}}(f)/P_{\text{sky}}(f) - 1)$$

A somewhat more laborious, but more accurate method would be to apply the procedures to derive system and zenith temperatures to each frequency of the spectrum. But this can be done with a bit of programming work ...

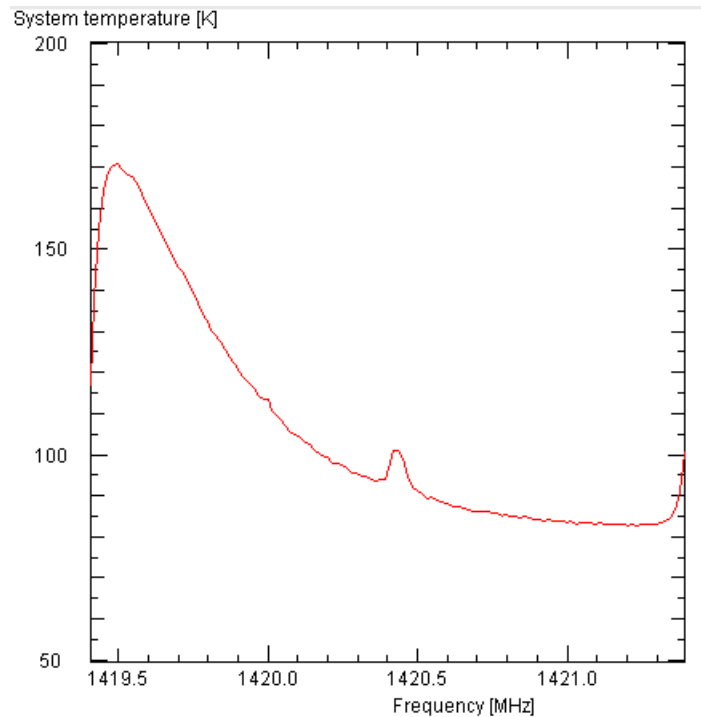

Fig.19: Flux calibration of the spectra, computed from the spectra of the flux calibrator and of the empty sky at elevation 60° . The bump in the middle is weak emission from the Milky Way, which one cannot avoid.

7. Decomposition of spectra: spiral arms

The reduced spectra can be used for a more detailed interpretation by trying to match the spectrum by a sum of gaussian profiles – of different radial velocity, height, and width – which represent the emission components, i.e. the spiral arms. The width of a component yields the velocity dispersion within an arm. What width is necessary? Is it possible to use a single value? How unique is such a decomposition?

8. Deprojection of spiral arms

If we observed the HI emission at all galactic longitudes, we have data characterized by longitude and radial velocity. If we further adopt a certain rotation curve – the simplest being one with constant speed – we can compute the galactocentric radius of every part of the spectra (l, v_{rad}) from the measured radial velocity by reversing the general formula, and thus get the position in the disc where this patch of emission comes from. If we assign to this position in the Plane – for simplicity – the measured intensity of this patch, we obtain a map of the Galactic Plane ...

Literature

Radio astronomy text books

- *T.L. Wilson, K.Rohlfs, S.Hüttemeister*, Tools of Radio Astronomy, Springer (several editions) very good text book, deals with all aspects in a very detailed way
- *B.F.Burke, F.Graham-Smith*, An Introduction to Radio Astronomy, Cambridge University Press, 1997: good introduction and text book
- *G.L.Verschuur, K.I.Kellermann*, Galactic and Extragalactic Radio Astronomy, Springer, 1974 (also older editions): albeit somewhat old, gives a good overview of methods and results
- *J.L.Pawsey, R.N.Bracewell*, Radio Astronomy, Clarendon Press, Oxford, 1955: old, but this good text book from the pioneer days covers well the basic subjects

Articles

- *C.Monstein*, Messungen der Mondtemperatur auf 10 GHz
http://www.e-callisto.org/GeneralDocuments/Moon_Temperatur/Mond2001V2German.pdf
oder <http://www.pa0ehg.com/extra/moontemp.pdf>
- *J.H.Piddington, H.C.Minnett*, Microwave Thermal Radiation from the Moon, 1949, Australian Journal of Scientific Research A, vol. 2, p.63

Weblinks

- NOAA Solar Radiofluxes: ftp://ftp.swpc.noaa.gov/pub/lists/radio/30day_rad.html
- Radiometry on 10 GHz: <http://www.astrophysik.uni-kiel.de/~koeppen/10GHz/>
- Spectrometry on 1420 MHz: <http://www.astrophysik.uni-kiel.de/~koeppen/Haystack/>
- Simulator for RoenneRadiometer:
<http://www.astrophysik.uni-kiel.de/~koeppen/JS/RRM/RRM.html>
with almost identical graphical user interface (GUI) and produces data in the same quality as the real instrument. The time of observation may be chosen freely, but data can only be recorded at current time.
- Simulator for Radiometry on 10 GHz:
<http://www.astrophysik.uni-kiel.de/~koeppen/10GHz/applets/trainer/>
- Simulator for Spectroscopy on 1420 MHz: <http://www.astrophysik.uni-kiel.de/~koeppen/JS/RSM/RSM.html> with almost the same GUI as RoenneSpectrometer. Simulated data has the same quality as the real instrument. The time of observation can be chosen freely, but data can only be recorded at current time..
- Planning your observations: <http://www.astrophysik.uni-kiel.de/~koeppen/JS/Scheduler.html> gives an overview when a source or a position is above the horizon.
- Galactic rotation: <http://www.astrophysik.uni-kiel.de/~koeppen/JS/MWGrotaion/>
- Spiral arms: <http://www.astrophysik.uni-kiel.de/~koeppen/Haystack/spirals.html>
- Position and Diameter of Sun and Moon: <http://www.astrophysik.uni-kiel.de/~koeppen/JS/SunMoon.html>
- Solar System bodies: <http://www.astrophysik.uni-kiel/~koeppen/orrery/>
JAVA Applet computes position, angular diameter and other properties.

General

- *A. Unsöld, B. Baschek*, Der neue Kosmos, Springer, 7. Aufl., 2002
- *H.H. Voigt*, Abriß der Astronomie, Wiley-VCH, 6. Aufl., 2012; also older editions